



Soluzioni per il sollevamento acque in campo
On the field water lifting solutions

LAND FLUID MOTION



Agricoltura
Bonifica
Acquacoltura
Agriculture
Land reclamation
Aquaculture



VENERONI
ADVANCED FLUID MOTION



LAND FLUID MOTION

Solleverare e convogliare l'acqua da diverse fonti, per ottimizzare le risorse idriche e migliorare la produzione agricola, per bonificare i terreni o movimentare grandi volumi: Veneroni offre una gamma completa di soluzioni per il sollevamento acque in campo, per rispondere a qualsiasi tipo di esigenza, dall'irrigazione dei terreni agricoli, al prosciugamento, fino al travaso per acquacoltura.

AGRICOLTURA

Irrigazione diretta, alimentazione canali d'irrigazione, allagamento risaie.

BONIFICA

Prosciugamento aree allagate, sollevamento acque di drenaggio.

ACQUACOLTURA

Travaso bacini di grandi volumi, prosciugamento.

Lifting and carrying water from different sources, to optimize water resources and improve agricultural production, but also for land reclamation or water handling: Veneroni offers a complete range of on the field water lifting solutions, to meet any type of need, from irrigation of agricultural land, to draining, to water transfer for aquaculture.

AGRICULTURE

Direct irrigation, supplying water to irrigation canals, flooding of rice fields.

LAND RECLAMATION

Draining of flooded areas, lifting of drainage water.

AQUACULTURE

Transfer of large volumes, draining.



MOVING FORWARD

Siamo convinti che la ricerca dell'eccellenza e il continuo slancio verso l'innovazione siano parte integrante del nostro DNA. Il nostro reparto R&D è dotato di strumenti informatici all'avanguardia per il calcolo delle strutture; ogni progetto viene attentamente verificato nella nostra sala collaudo e poi testato direttamente sul campo, perché vogliamo essere sicuri di offrirvi sempre la massima qualità.

- **Software di modellazione CAD 3D**
- **Calcolo strutturale FEA**
- **Calcolo fluido-dinamico computazionale CFD**
- **Collaudo in sala prove**

We believe that the pursuit of excellence and the continuous drive towards innovation are an integral part of our DNA. Our R&D department is equipped with state-of-the-art IT tools for structural analysis; all our projects are carefully checked in our testing room and then tested directly on the field, because we want to be sure to offer you the highest quality.

- **3D CAD modeling software**
- **FEA structural analysis**
- **CFD Computational Fluid Dynamics analysis**
- **Full inspection in Testing Room**

Calcolo FEA
FEA analysis

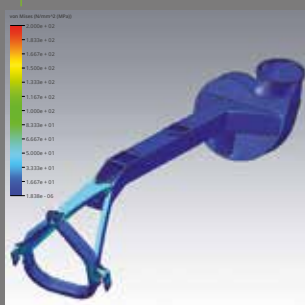

Calcolo CFD
CFD analysis

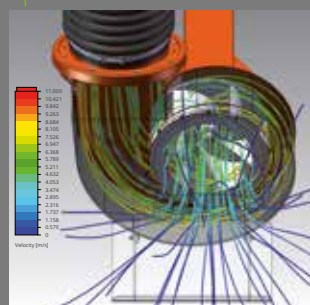

Sala prove
Testing Room



POMPE MOBILI

MOBILE PUMPS



Corpo pompa con idraulica centrifuga [ATN | ATR | ATS].

Elevata modulabilità di pompaggio e grande flessibilità di utilizzo.

Corpo pompa con idraulica a elica [ETR].

Grandi portate a potenze ridotte con notevole risparmio energetico.

Centrifugal pump [ATN | ATR | ATS].

High pumping versatility and great flexibility of use.

Propeller pump [ETR].

High flow at low power with significant energy saving.



Trasmissione lubrificata a grasso con supporto di fondo a tenuta stagna.

Estrema resistenza alle sollecitazioni, massima affidabilità anche in caso di funzionamento a secco, manutenzione semplice e agevole.

Grease lubricated transmission with watertight bottom support.

Extreme resistance to stress, maximum reliability even in dry operation, simple and easy maintenance.



Estensione idraulica del tubo di mandata per la massima adattabilità alle diverse condizioni di lavoro [ATS].

Componenti appositamente progettati per ottimizzare l'efficacia del prodotto e valorizzarne le caratteristiche.

Hydraulic extension of the delivery pipe for maximum adaptability to different working conditions [ATS].

Parts specifically designed to optimize product's effectiveness and enhance its features.



Verniciatura con fondo epossidico ai fosfati di zinco e smalto poliuretano.

Elevata protezione superficiale dei materiali.

Carpenteria zincata a caldo.

Alta resistenza alla corrosione e agli agenti abrasivi.

Painting with zinc phosphate epoxy primer and polyurethane enamel.

High surface materials' protection.

Hot galvanized carpentry.

High resistance to corrosion and abrasive agents.

Scendi in campo e aspira al massimo

Take the field and direct the flow



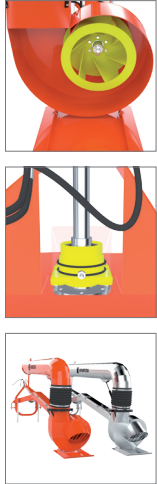

La pompa ATN, dotata di idraulica di tipo centrifugo, garantisce un'elevata modulabilità di pompaggio e una grande flessibilità di utilizzo anche con bassa sommergenza. Il tubo di mandata orientabile manualmente in orizzontale con sollevamento idraulico offre la massima semplicità per adattarsi alla configurazione di pompaggio.

ATN pump, a centrifugal type of pump, grants high modulability when pumping and great flexibility of use even with low submergence. The delivery pipe, manually adjustable in horizontal with hydraulic lifting, offers maximum simplicity to adapt to the specific pumping configuration.

CARATTERISTICHE | FEATURES

Modello Model	Giri/Min RPM	P [kW]	Q [l/s]	150	200	250	300	350	400	450	500
			Q [l/min]	9000	12000	15000	18000	21000	24000	27000	30000
			Q [mc/h]	540	720	900	1080	1260	1440	1620	1800
ATN 25	540	35	P [kW]	19,5	21,5	22					
			H [m]	6,2	5	3,2					
ATN 30	540	40	P [kW]	22	23	25	26				
			H [m]	7,5	6,4	5,3	3,6				
ATN 35	540	52	P [kW]	28	29	30	31	31	31,5	32	
			H [m]	7,6	7,1	6,4	5,6	4,7	3,6	2,3	
ATN 40	540	62	P [kW]	33,5	35	36	37	38	38,5	39	39
			H [m]	8,4	8	7,4	6,7	5,9	5	3,9	2,7

DIMENSIONI | DIMENSIONS

Modello Model	D [mm]	Telaio Frame [m]	H [m]	A [mm]	B [mm]	Peso Weight [kg]
ATN 25	250	3	1,5	3350	2810	310
		4	2,3	4350	3810	350
		5	3,1	5350	4810	410
		6	3,8	6350	5810	480
ATN 30	300	3	1,6	3400	2825	330
		4	2,3	4400	3825	420
		5	3,1	5400	4825	470
ATN 35	350	6	3,9	6400	5825	570
		3	1,7	3600	2805	440
		4	2,5	4600	3805	550
ATN 40	400	5	3,2	5600	4805	610
		6	4	6600	5805	680
		3	1,7	3600	2855	500
ATN 40	400	4	2,5	4600	3855	610
		5	3,2	5600	4855	670
		6	4	6600	5855	770

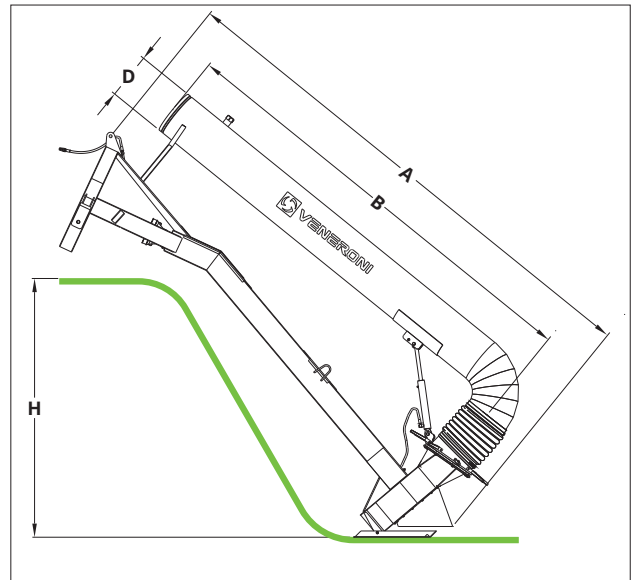



La pompa ATR, dotata di idraulica di tipo centrifugo, garantisce un'elevata modulabilità di pompaggio e una grande flessibilità di utilizzo anche con bassa sommergenza. Il tubo di mandata orientabile idraulicamente consente di direzionare agevolmente il flusso in mandata per una maggiore praticità di utilizzo nelle diverse postazioni di pompaggio.

ATR pump, a centrifugal type of pump, grants high modulability when pumping and great flexibility of use even with low submergence. The hydraulically adjustable delivery pipe allows to direct the flow for easier operation in the different pumping locations.

CARATTERISTICHE | FEATURES

Modello Model	Giri/Min RPM	P [kW]	Q [l/s]	150	200	250	300	350	400	450	500	550	600	650	700	750
			Q [l/min]	9000	12000	15000	18000	21000	24000	27000	30000	33000	36000	39000	42000	45000
			Q [mc/h]	540	720	900	1080	1260	1440	1620	1800	1980	2160	2340	2520	2700
ATR 25	540	35	P [kW]	19,5	21,5	22										
			H [m]	6,2	5	3,2										
ATR 30	540	40	P [kW]	22	23	25	26									
			H [m]	7,5	6,4	5,3	3,6									
ATR 35	540	52	P [kW]	28	29	30	31	31	31,5	32						
			H [m]	7,6	7,1	6,4	5,6	4,7	3,6	2,3						
ATR 40	540	62	P [kW]	33,5	35	36	37	38	38,5	39	39					
			H [m]	8,4	8	7,4	6,7	5,9	5	3,9	2,7					
ATR 50	540	88	P [kW]			60	63	65	66	67	68	69	70	70,5	71	71
			H [m]			10,3	9,9	9,4	8,9	8,2	7,5	6,7	5,8	4,8	3,8	2,6

DIMENSIONI | DIMENSIONS

Modello Model	D [mm]	Telaio Frame [m]	H [m]	A [mm]	B [mm]	Peso Weight [kg]
ATR 25	250	3	1,5	3350	2810	330
		4	2,3	4350	3810	370
		5	3,1	5350	4810	430
		6	3,8	6350	5810	500
ATR 30	300	3	1,6	3400	2825	350
		3,5	1,9	3900	3375	390
		4	2,3	4400	3825	440
		5	3,1	5400	4825	490
ATR 35	350	6	3,9	6400	5825	590
		3	1,7	3600	2805	460
		3,5	2,1	4100	3305	500
		4	2,5	4600	3805	570
ATR 40	400	5	3,2	5600	4805	630
		6	4	6600	5805	700
		3	1,7	3600	2855	520
		3,5	2,1	4100	3355	570
ATR 50	500	4	2,5	4600	3855	630
		5	3,2	5600	4855	690
		6	4	6600	5855	790
		4	2,6	4740	3950	890
		5	3,4	5740	4950	1030

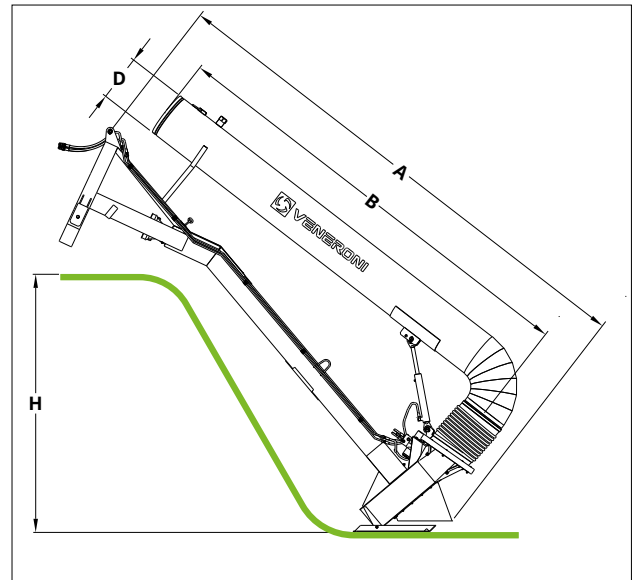

ATS

Pompa centrifuga a trattore con rotazione idraulica e tubo telescopico

Tractor driven centrifugal pump with hydraulic rotation and telescopic pipe



La pompa ATS, dotata di idraulica di tipo centrifugo, garantisce un'elevata modularità di pompaggio e una grande flessibilità di utilizzo anche con bassa sommergenza. Il tubo di mandata orientabile idraulicamente con tubo telescopico idraulico allungabile di 1,5 m garantisce la massima adattabilità adeguandosi con precisione alle svariate configurazioni di lavoro.

ATS pump, a centrifugal type of pump, grants high modularity when pumping and great flexibility of use even with low submergence. The hydraulically adjustable delivery pipe with a hydraulic telescopic pipe extensible of 1,5 meters grants the best adaptability, suiting with precision to the different working configurations.

CARATTERISTICHE | FEATURES

Modello Model	Giri/Min RPM	P [kW]	Q [l/s]	150	200	250	300	350	400	450	500
			Q [l/min]	9000	12000	15000	18000	21000	24000	27000	30000
			Q [mc/h]	540	720	900	1080	1260	1440	1620	1800
ATS 30	540	40	P [kW]	22	23	25	26				
			H [m]	7,5	6,4	5,3	3,6				
ATS 35	540	52	P [kW]	28	29	30	31	31	31,5	32	
			H [m]	7,6	7,1	6,4	5,6	4,7	3,6	2,3	
ATS 40	540	62	P [kW]	33,5	35	36	37	38	38,5	39	39
			H [m]	8,4	8	7,4	6,7	5,9	5	3,9	2,7

DIMENSIONI | DIMENSIONS

Modello Model	D [mm]	Telaio Frame [m]	H [m]	A [mm]	B [mm]	Peso Weight [kg]
ATS 30	300	3,5	1,9	3900	3375	570
		4	2,3	4400	3825	620
		5	3,1	5400	4825	670
ATS 35	350	3,5	2,1	4100	3410	580
		4	2,5	4600	3910	760
		5	3,2	5600	4910	820
ATS 40	400	3,5	2,1	4100	3470	760
		4	2,5	4600	3970	800
		5	3,2	5600	4970	880

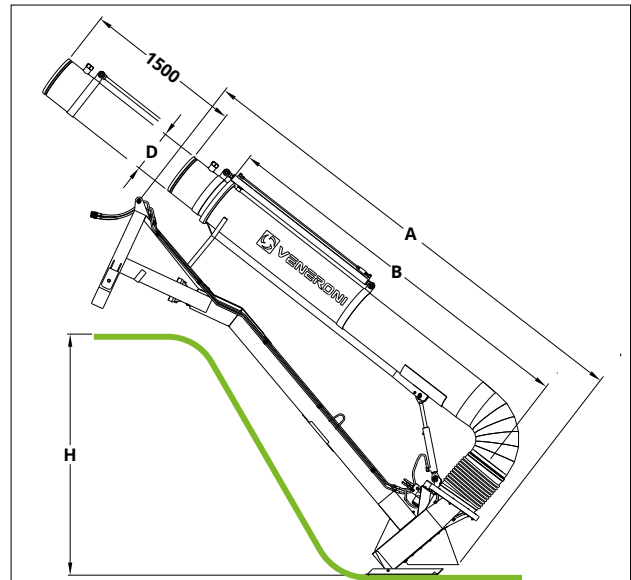

ETR

Pompa ad elica a trattore con rotazione idraulica

Tractor driven propeller pump with hydraulic rotation

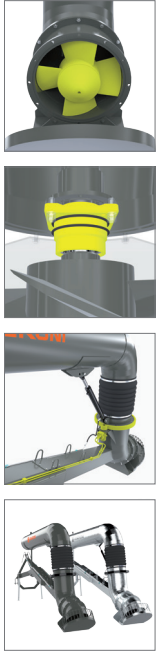

La pompa ETR, dotata di idraulica di tipo ad elica ad alta efficienza, raggiunge elevate portate richiedendo una potenza limitata e bassi consumi; la configurazione con doppia girante consente di raggiungere maggiore prevalenza. Il tubo di mandata orientabile idraulicamente consente di direzionare agevolmente il flusso in mandata per una maggiore praticità di utilizzo nelle diverse postazioni di pompaggio.

ETR pump, a propeller type of pump with high efficiency, reaches high flow requiring low power and energy saving; the configuration with double propeller allows to get to higher head. The hydraulically adjustable delivery pipe allows to direct the flow for easier operation in the different pumping location.

CARATTERISTICHE | FEATURES

Modello Model	Giri/Min RPM	P [kW]	Q [l/s]	600	650	700	750	800	850	900	950	1000
			Q [l/min]	36000	39000	42000	45000	48000	51000	54000	57000	60000
			Q [mc/h]	2160	2340	2520	2700	2880	3060	3240	3420	3600
ETR 50-1	750	58	P [kW]	52	51	50	48	46	43	40	36	32
			H [m]	5,8	5,5	5,2	4,8	4,4	3,9	3,4	2,8	2,2
ETR 50-2	750	110	P [kW]	103	101	99	95	91	85	80	72	63
			H [m]	11,6	11	10,4	9,6	8,8	7,8	6,8	5,6	4,4

DIMENSIONI | DIMENSIONS

Modello Model	D [mm]	Telaio Frame [m]	H [m]	A [mm]	B [mm]	Peso Weight [kg]
ETR 50-1	500	5	3	5350	3450	960
		6	3,8	6370	4450	1070
ETR 50-2	500	5	3,3	5680	3450	1150
		6	4	6700	4450	1260

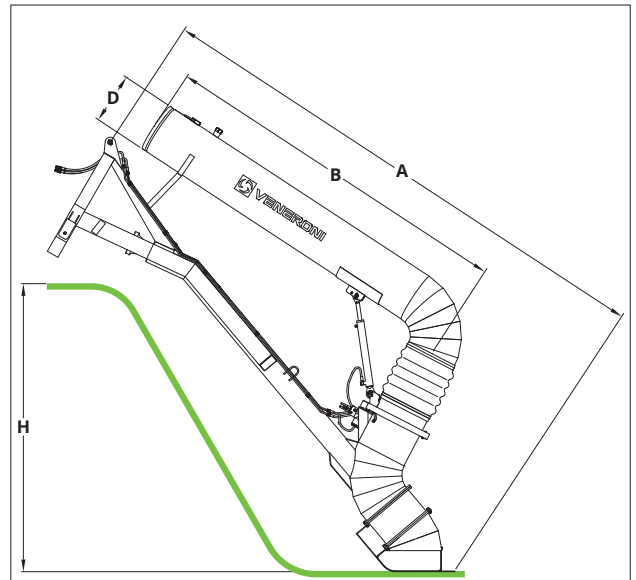

POMPE FISSE

STATIONARY PUMPS



Corpo pompa con idraulica centrifuga a singola o doppia aspirazione.

Elevata modulabilità per il massimo rendimento nel punto di lavoro richiesto, massima versatilità nelle diverse condizioni di lavoro.

Centrifugal pump with single or double suction.

High pumping versatility for maximum efficiency at the required work point, maximum adaptability to different working conditions.

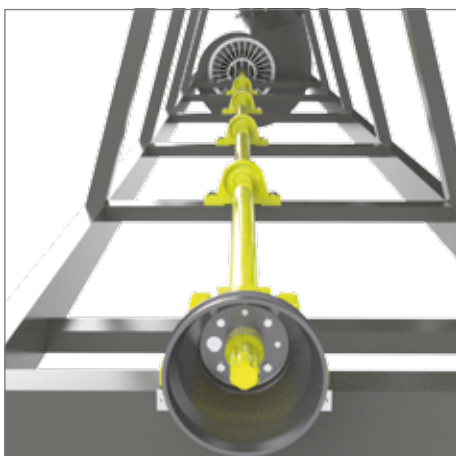

Trasmissione lubrificata a grasso con supporto di fondo a tenuta stagna.

Estrema resistenza alle sollecitazioni, massima affidabilità anche in caso di funzionamento a secco, manutenzione semplice e agevole.

Grease lubricated transmission with watertight bottom support.

Extreme resistance to stress, maximum reliability even in dry operation, simple and easy maintenance.

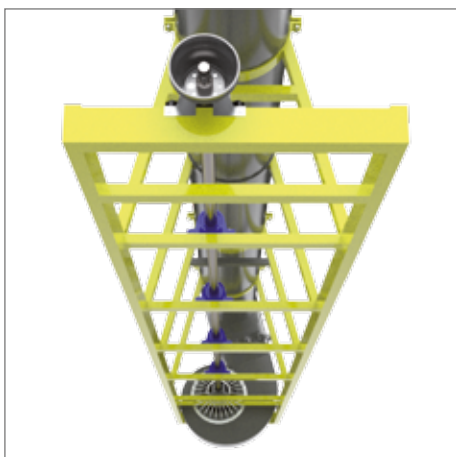

Telaio con robusta struttura in acciaio a traliccio.

Componenti appositamente realizzati e verificati per ogni singolo progetto.

Sturdy trellis steel frame.

Parts specifically made and checked for every single project.

Progettate per puntare in alto
Designed to aim high





La nostra pompa fissa è uno strumento progettato su misura per le vostre esigenze, perché uniche sono le caratteristiche idrogeologiche nelle quali la pompa si troverà a operare. Analizzando il caso specifico attraverso uno studio di fattibilità e applicando le soluzioni tecniche ormai consolidate da decenni di esperienza, siamo in grado di proporre il migliore progetto di realizzazione.

Our stationary pump is a tailor-made machine designed to meet your needs, as the hydrogeological features in which the pump will work are unique. By examining the specific case through a feasibility study and applying the technical solutions we have strengthened over years of experience, we are able to offer the best project.

Azionamento	Trattore / Gruppo motofrizione / Motore elettrico
Installazione	Fissa
Tipo pompa	Centrifuga
Trasmissione	Lubrificata a grasso / In bagno d'olio con tenuta meccanica al widia-widia

Drive	Tractor / Motor clutch set / Electric motor
Installation	Stationary
Pump type	Centrifugal
Transmission	Grease lubricated / Oil bath with widia-widia mechanical seal

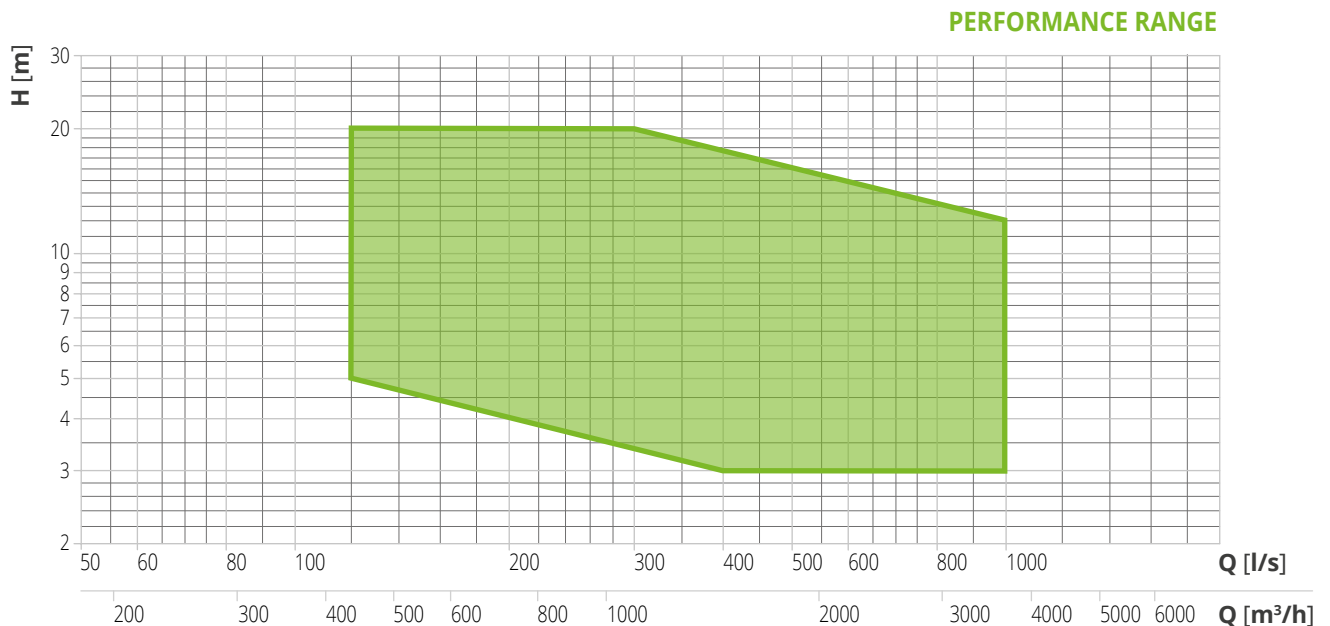



Pompa ABN 35

Lunghezza 5 metri, portata 300 l/s, prevalenza 7,5 metri, trasmissione in bagno d'olio, corpo pompa rinforzato con girante aperta, azionamento con motore elettrico.

ABN 35 Pump

Length 5 meters, flow 300 l/s, head 7,5 meters, oil bath transmission, reinforced pump body with open impeller, electric motor driven.



Pompa ABN 40

Lunghezza 10 metri, portata 400 l/s, prevalenza 8,2 metri, trasmissione in bagno d'olio, corpo pompa ad alto rendimento, azionamento con gruppo motofrizione.

ABN 40 Pump

Length 10 meters, flow 400 l/s, head 8,2 meters, oil bath transmission, high efficiency pump body, motor clutch driven.



Pompa ABN 45

Lunghezza 19 metri, portata 400 l/s, prevalenza 9 metri, trasmissione in bagno d'olio, corpo pompa ad alto rendimento, azionamento con motore elettrico.

ABN 45 Pump

Length 19 meters, flow 400 l/s, head 9 meters, oil bath transmission, high efficiency pump body, electric motor driven.



Pompa ABN 60

Lunghezza 9 metri, portata 775 l/s, prevalenza 8,4 metri, trasmissione lubrificata a grasso, corpo pompa a doppia aspirazione, azionamento a trattore.

ABN 60 Pump

Length 9 meters, flow 775 l/s, head 8,4 meters, grease lubricated transmission, body pump with double suction, tractor driven.





WIDE FLUID MOTION

■ **LAND** FLUID MOTION

RAW FLUID MOTION



Spinti dal flusso della passione dal 1957

Driven by the flow of passion since 1957

VENERONI srl
Via della Resistenza, 8
26020 Formigara (CR) - Italy
Tel. +39 0374 78036
Fax +39 0374 78314
info@veneroni.it
www.veneroni.it

